

Part Number: WP1533AA/ID14V-W152

High Efficiency Red

Features

- Outstanding material efficiency.
- Reliable and rugged.
- Low current capability.
- Housing UL rating: 94V-0.
- Housing material: type 66 nylon.
- 14V internal resistor.
- RoHS compliant.

Description

The High Efficiency Red source color devices are made with Gallium Arsenide Phosphide on Gallium Phosphide Orange Light Emitting Diode.

Package Dimensions

Fig.1 :

ANODE LEAD :RED INSULATION LEAD ,24 AWG ,UL#1007,Ø1.45mm, TINNED OVERCOATED WIRE , STRIP 12.7mm.

Fig. 2 :

CATHODE LEAD :BLACK INSULATION LEAD ,24 AWG,UL#1007 ,Ø1.45mm, TINNED OVERCOATED WIRE , STRIP 12.7mm.

Fig.3 :

STAKING TO FIX THE HOLDER AND LED .

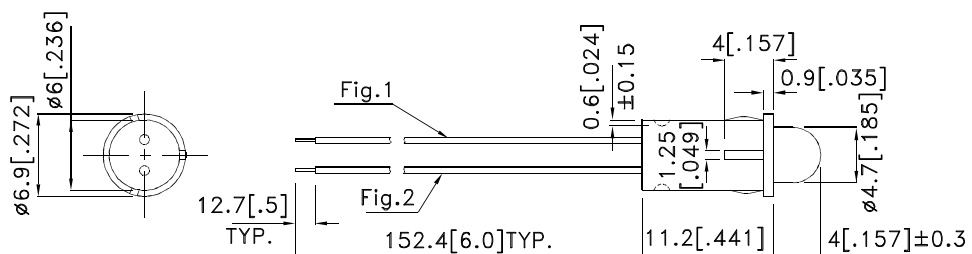

Remark:

Recommended panel mount hole diameter $\phi = 6.30 - 6.35$ mm;
panel thickness 1.0mm.

Notes:

1. All dimensions are in millimeters (inches).
2. Tolerance is ± 0.25 (0.01") unless otherwise noted.
3. Lead spacing is measured where the leads emerge from the package.
4. The specifications, characteristics and technical data described in the datasheet are subject to change without prior notice.



Selection Guide

Part No.	Dice	Lens Type	Iv (mcd) [2] V= 14V		Viewing Angle [1]
			Min.	Typ.	2θ1/2
WP1533AA/ID14V-W152	High Efficiency Red (GaAsP/GaP)	Red Diffused	15	50	60°

Notes:

1. θ1/2 is the angle from optical centerline where the luminous intensity is 1/2 of the optical peak value.
2. Luminous intensity/ luminous Flux: +/-15%.

Electrical / Optical Characteristics at TA=25°C

Symbol	Parameter	Device	Typ.	Max.	Units	Test Conditions
λ _{peak}	Peak Wavelength	High Efficiency Red	627		nm	V _F =14V
λ _D [1]	Dominant Wavelength	High Efficiency Red	625		nm	V _F =14V
Δλ _{1/2}	Spectral Line Half-width	High Efficiency Red	45		nm	V _F =14V
I _F	Forward Current	High Efficiency Red	10.5	13.5	mA	V _F =14V
I _R	Reverse Current	High Efficiency Red		10	μA	V _R = 5V

Note:

- 1.Wavelength: +/-1nm.

Absolute Maximum Ratings at TA=25°C

Parameter	High Efficiency Red	Units
Power dissipation	160	mW
Forward Voltage	16	V
Reverse Voltage	5	V
Operating Temperature	-40°C To +70°C	
Storage Temperature	-40°C To +85°C	
Lead Solder Temperature [1]	260°C For 3 Seconds	
Lead Solder Temperature [2]	260°C For 5 Seconds	

Notes:

1. 2mm below package base.
2. 5mm below package base.

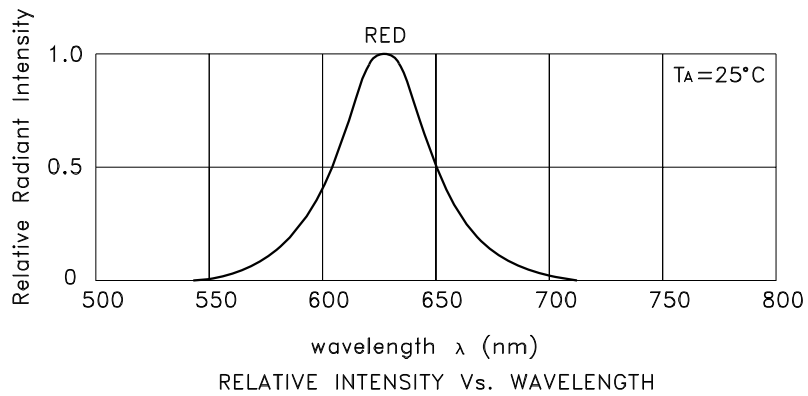

High Efficiency Red WP1533AA/ID14V-W152

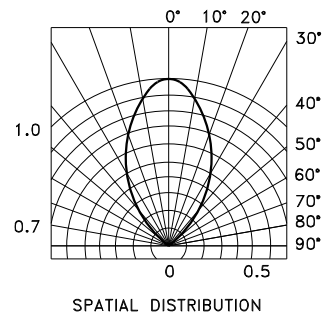
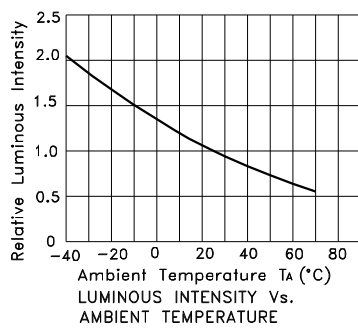
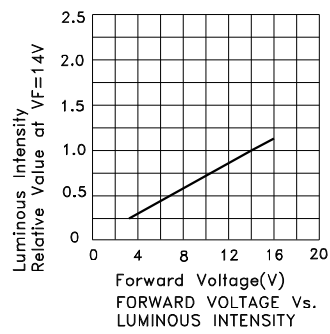
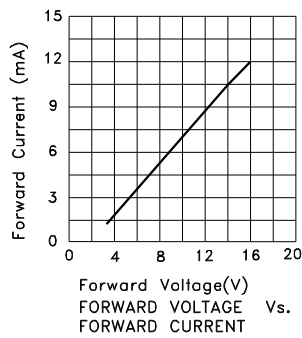

PACKING & LABEL SPECIFICATIONS

WP1533AA/ID14V-W152

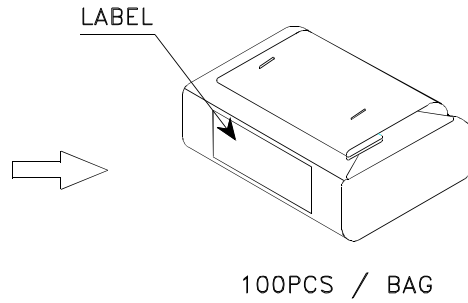
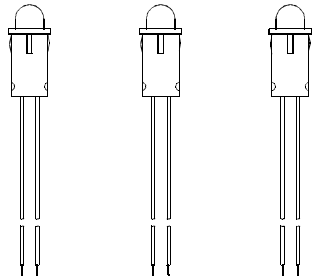

4K / 9# BOX

OUTSIDE LABEL

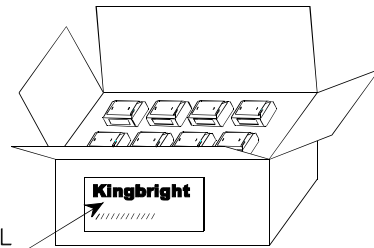
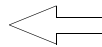

OUTSIDE LABEL

2K / 5# BOX

<h1>Kingbright</h1>	
P/NO: WP1533AAxxx	
QTY: 100 pcs	Q.C. Q C XX XX XXXX PASSED
S/N: XXXX	
CODE: XXX	
LOT NO:	
 XXXXXXXXXXXX	
RoHS Compliant	

PRECAUTIONS

- The lead pitch of the LED must match the pitch of the mounting holes on the PCB during component placement. Lead-forming may be required to insure the lead pitch matches the hole pitch. Refer to the figure below for proper lead forming procedures.

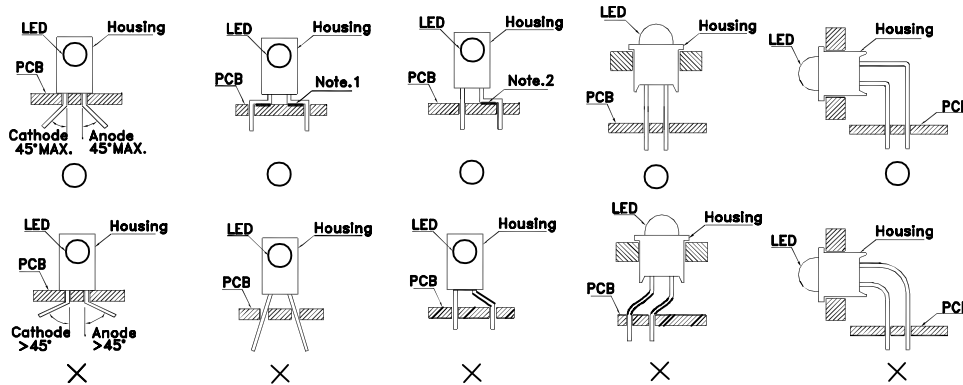

”○” Correct mounting method ”×” Incorrect mounting method

- During soldering, component covers and holders should leave clearance to avoid placing damaging stress on the LED during soldering.

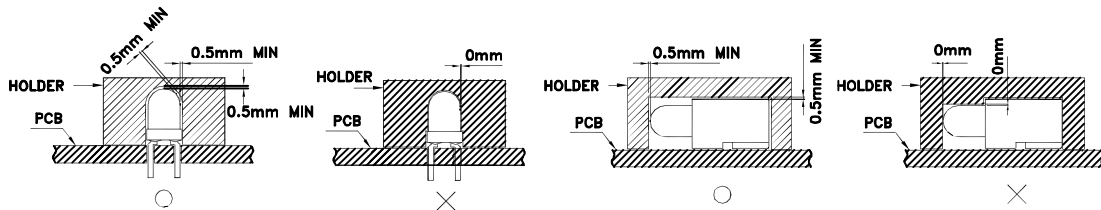

- The tip of the soldering iron should never touch the lens epoxy.
- Through-hole LEDs are incompatible with reflow soldering.
- If the LED will undergo multiple soldering passes or face other processes where the part may be subjected to intense heat, please check with Kingbright for compatibility.
- Recommended Wave Soldering Profile for Kingbright Thru-Hole Products

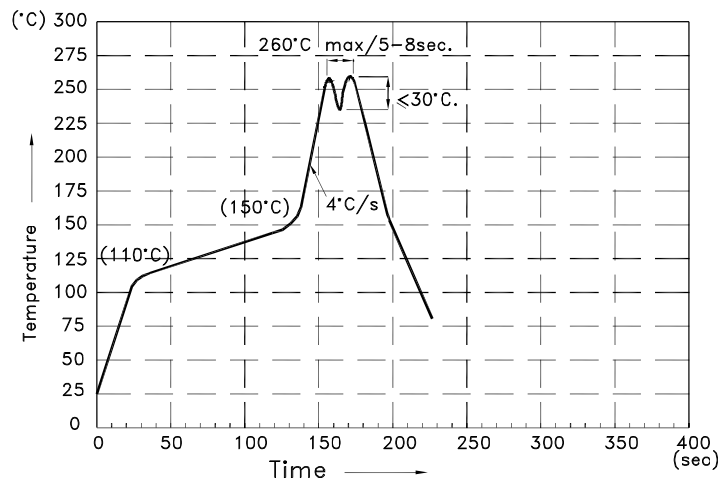

NOTES:

- Recommend the wave temperature 245°C~260°C. The maximum soldering temperature should be less than 260°C.
- Do not apply stress on epoxy resins when temperature is over 85°C.
- The soldering profile apply to the lead free soldering (Sn/Cu/Ag alloy).
- During wave soldering, the PCB top-surface temperature should be kept below 105°C.
- No more than once.