

PRELIMINARY SPEC

Part Number: APTK2012RWC/Z-F01 WHITE



ATTENTION
OBSERVE PRECAUTIONS
FOR HANDLING
ELECTROSTATIC
DISCHARGE
SENSITIVE
DEVICES

Features

- 2.0mmx1.25mm SMT LED, 0.75mm thickness.
- Low power consumption.
- Wide viewing angle.
- Ideal for backlight and indicator.
- Various colors and lens types available.
- Package : 2000pcs / reel.
- Moisture sensitivity level : level 4.
- Electrostatic discharge threshold (HBM):1000V.
- Typ. color temperature:6500K
- Color coordinates:x=0.31,y=0.31 acc. to CIE1931(white).
- Optical efficiency:38.6 lm/W(typ.)
- Color reproduction index:80
- RoHS compliant.

Description

The source color devices are made with InGaN Light Emitting Diode.

Static electricity and surge damage the LEDs.

It is recommended to use a wrist band or anti-electrostatic glove when handling the LEDs.

All devices, equipment and machinery must be electrically grounded.

Applications

- traffic signaling.
- backlighting (illuminated advertising , general lighting).
- interior and exterior automotive lighting.
- substitution of micro incandescent lamps.
- reading lamps.
- signal and symbol luminaire for orientation.
- marker lights (e.g. steps, exit ways, etc).
- decorative and entertainment lighting.
- indoor and outdoor commercial and residential architectural lighting.

Package Dimensions

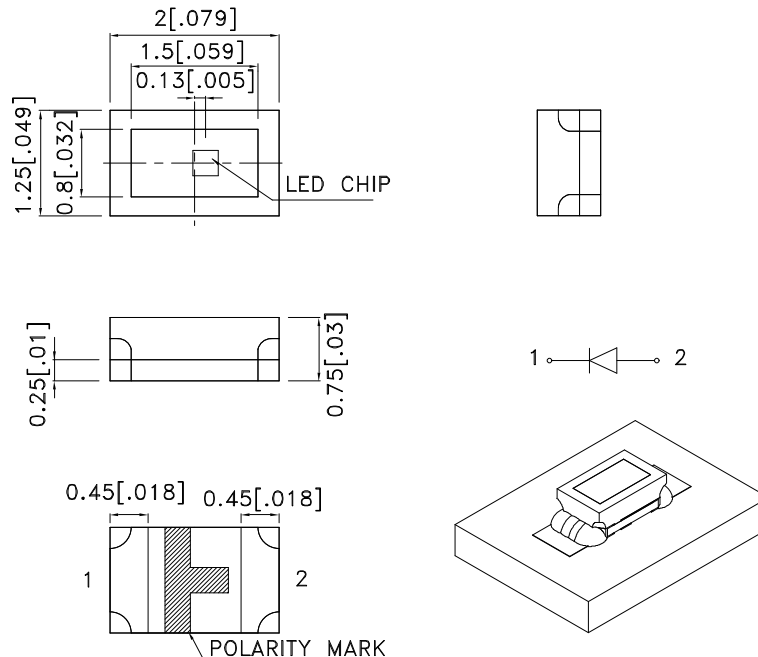

Notes:

1. All dimensions are in millimeters (inches).
2. Tolerance is ± 0.1 (0.004") unless otherwise noted.
3. Specifications are subject to change without notice.
4. The device has a single mounting surface. The device must be mounted according to the specifications.



Selection Guide

Part No.	Dice	Lens Type	luminous Intensity Note2 Iv(mcd) @ 20mA		Φ_v (mIm) Note3 @ 20mA		Viewing Angle Note1
			Min.	Typ.	Min.	Typ.	2 θ 1/2
APTK2012RWC/Z-F01	WHITE (InGaN)	WATER CLEAR	480	800	1440	2471	110°

Absolute Maximum Ratings at T_A=25°C

Parameter	Symbol	Value	Unit
Power dissipation	P _t	111	mW
Reverse Voltage	V _R	5	V
Junction temperature	T _J	110	°C
Operating Temperature	T _{op}	-40 To +85	°C
Storage Temperature	T _{stg}	-40 To +100	°C
DC Forward Current	I _F	30	mA
Peak Forward Current Note4	I _{FM}	100	mA
Thermal resistance Junction/ambient Note5	R _{th JA}	350	°C/W
Junction/solder point	R _{th JS}	130	°C/W

Notes:

1. θ 1/2 is the angle from optical centerline where the luminous intensity is 1/2 the optical centerline value.
2. Luminous intensity is measured by a current pulse of 10ms at a tolerance of $\pm 15\%$.
3. The typical data of Luminous Flux can only reflect statistical figures, actual parameters of individual product could differ from the typical data. For the purpose of product enhancement, the typical data is subject to change without prior notice.
4. 1/10 Duty Cycle, 0.1ms Pulse Width.
5. R_{th}(J-A) Results from mounting on PC board FR4 (pad size ≥ 16 mm² per pad),

Electrical / Optical Characteristics at T_A=25°C

Parameter	Symbol	Value	Unit
Chromaticity coordinate x acc.to CIE1931 I _F =20mA [Typ.]	χ Note1	0.31	-
Chromaticity coordinate y acc.to CIE1931 I _F =20mA [Typ.]	γ Note1	0.31	-
Forward Voltage I _F =20mA [Min.]	V _F Note2	2.7	V
Forward Voltage I _F =20mA [Typ.]		3.2	
Forward Voltage I _F =20mA [Max.]		3.7	
Reverse Current (V _R =5V) [Typ.]	I _R	0.01	μ A
Reverse Current (V _R =5V) [Max.]		10	
Temperature coefficient of x I _F =20mA, -10°C \leq T \leq 100°C [Typ.]	TC _x	-0.1	10 ⁻³ /°C
Temperature coefficient of y I _F =20mA, -10°C \leq T \leq 100°C [Typ.]	TC _y	-0.2	10 ⁻³ /°C
Temperature coefficient of V _F I _F =20mA, -10°C \leq T \leq 100°C [Typ.]	TC _v	-2.5	mV/°C

Notes:

1. Chromaticity coordinates are measured by a current pulse of 20ms with a tolerance of ± 0.01 in X and Y color coordinates.
2. Forward voltage is measured with a current pulse of 10ms at a tolerance of $\pm 0.1V$.

Brightness codes

Code.	luminous Intensity ^{Note1} Iv(mcd) @ 20mA		Φ_v (mlm) ^{Note2} @ 20mA
	Min.	Max.	Typ.
S	480	750	1852
T	650	1100	2338
U	900	1500	3224

Notes:

- Luminous intensity is measured by a current pulse of 10ms at a tolerance of $\pm 15\%$.
- The typical data of Luminous Flux can only reflect statistical figures, actual parameters of individual product could differ from the typical data. For the purpose of product enhancement, the typical data is subject to change without prior notice.

White

APTK2012RWC/Z-F01

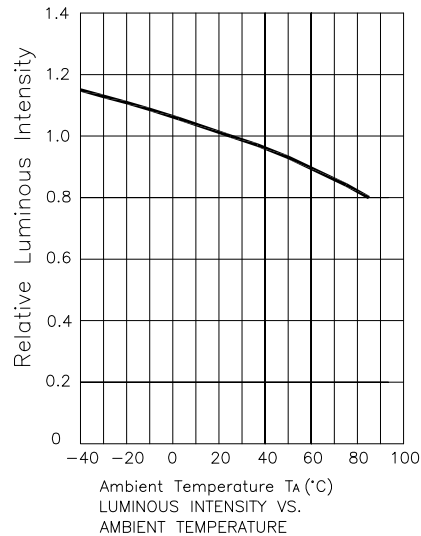
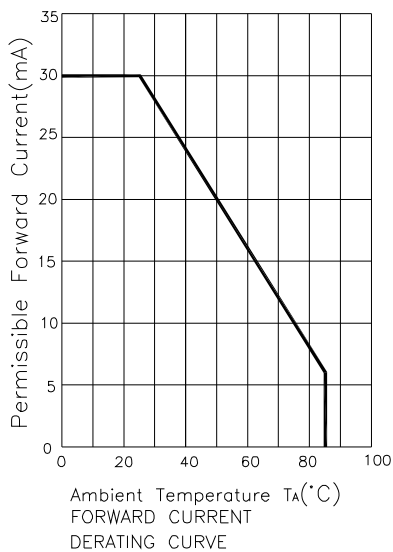
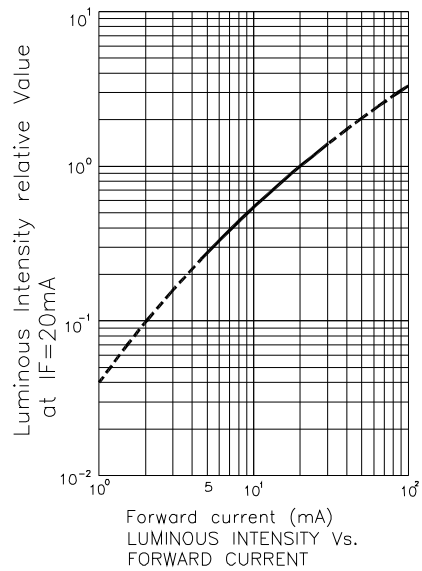
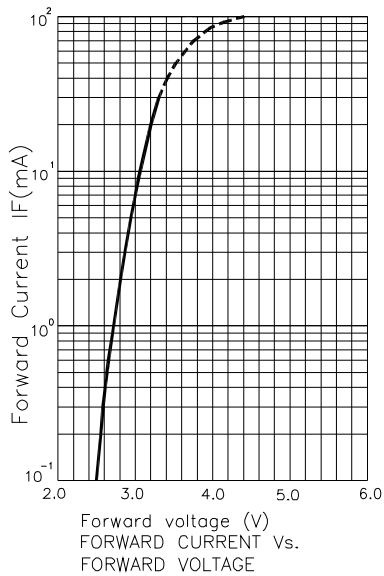

APTK2012RWC/Z-F01

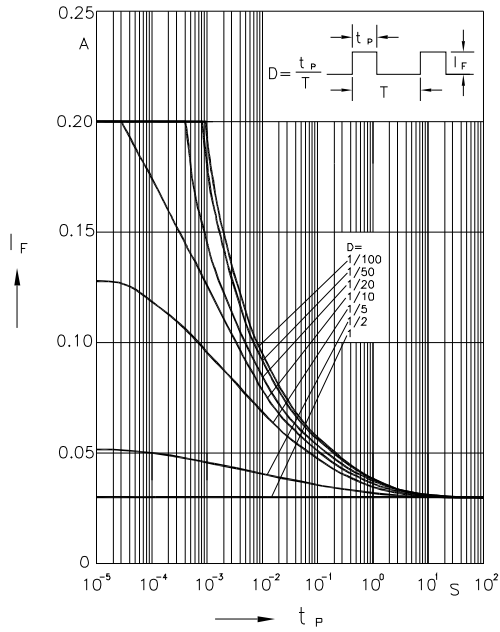

Permissible Pulse Handling Capability
Duty cycle $D = \text{parameter}$, $T_A = 25^\circ\text{C}$

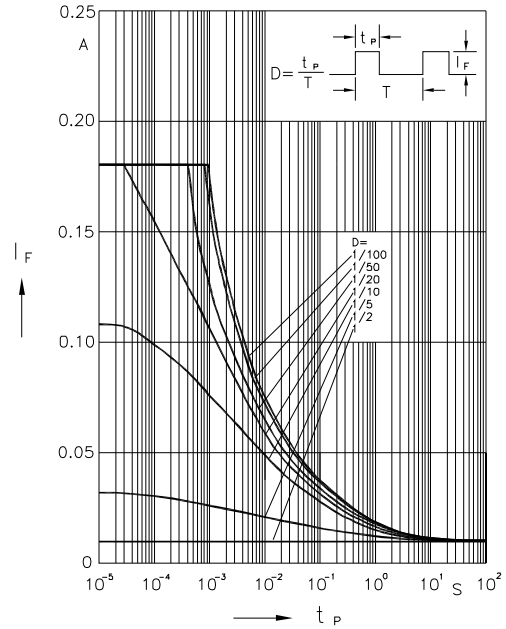

Permissible Pulse Handling Capability
Duty cycle $D = \text{parameter}$, $T_A = 85^\circ\text{C}$

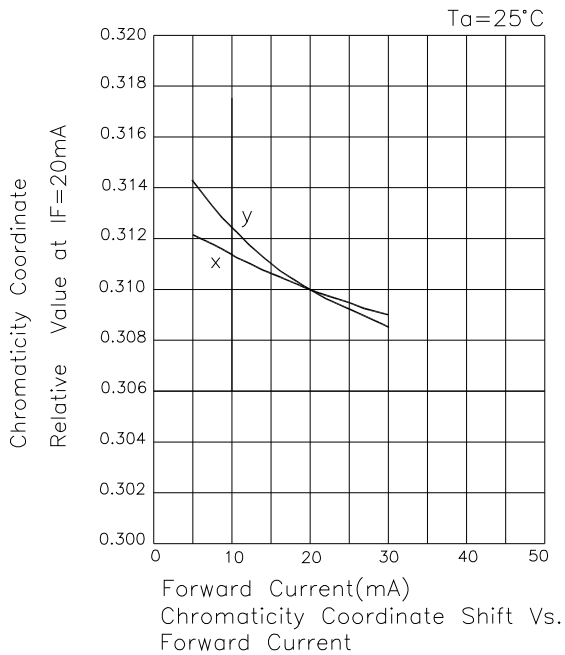

Forward Current (mA)
Chromaticity Coordinate Shift Vs. Forward Current

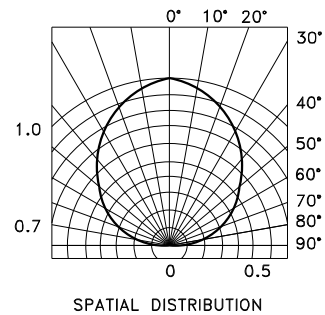
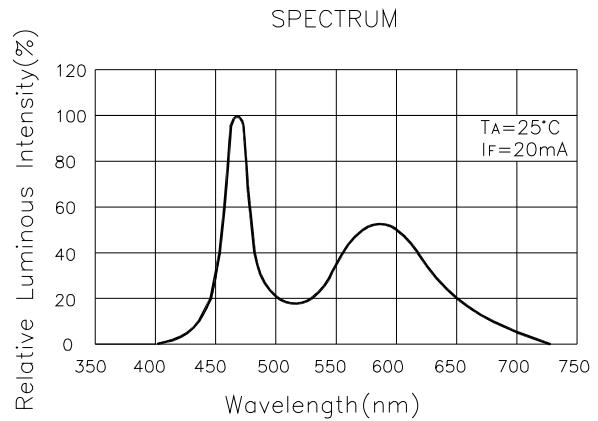

APTK2012RWC/Z-F01

White CIE

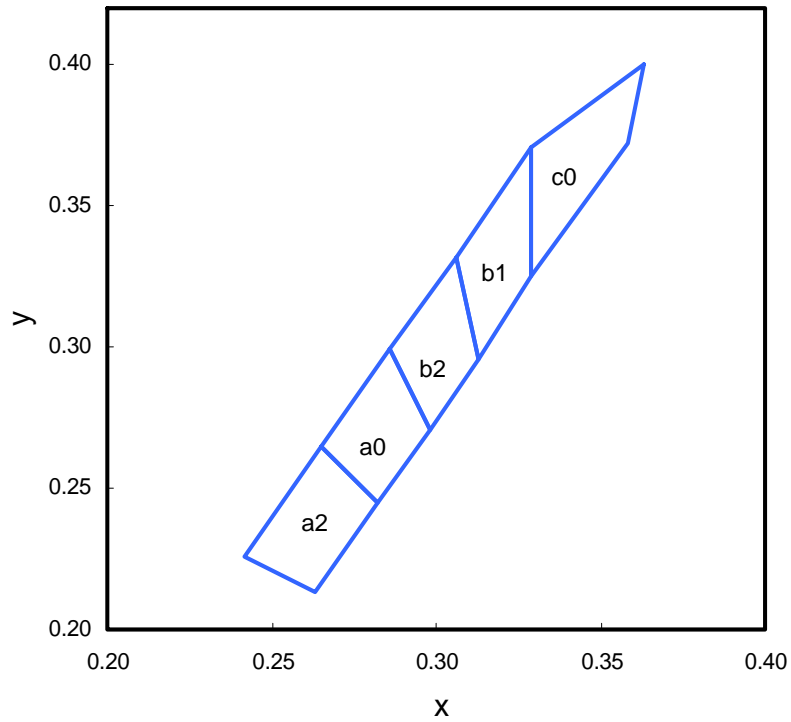

Rank a2				
X	0.263	0.282	0.265	0.242
Y	0.213	0.245	0.265	0.226

Rank a0				
X	0.282	0.298	0.286	0.265
Y	0.245	0.271	0.299	0.265

Rank b2				
X	0.298	0.313	0.306	0.286
Y	0.271	0.296	0.332	0.299

Rank b1				
X	0.313	0.329	0.329	0.306
Y	0.296	0.325	0.371	0.332

Rank c0				
X	0.329	0.358	0.363	0.329
Y	0.325	0.372	0.400	0.371

APTK2012RWC/Z-F01

Reflow Soldering Profile For Lead-free SMT Process.

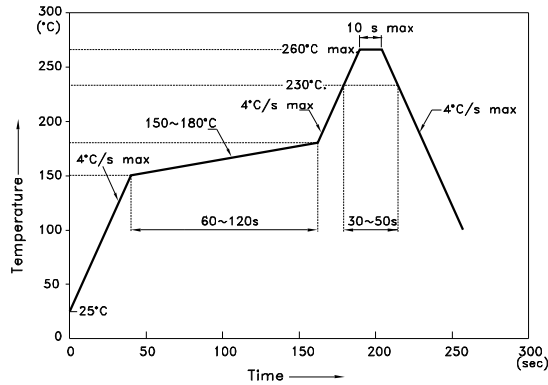

NOTES:

1. We recommend the reflow temperature 245°C(+/-5°C). The maximum soldering temperature should be limited to 260°C.
2. Don't cause stress to the epoxy resin while it is exposed to high temperature.
3. Number of reflow process shall be 2 times or less.

Recommended Soldering Pattern (Units : mm; Tolerance: ±0.1)

Pad design for improved heat dissipation

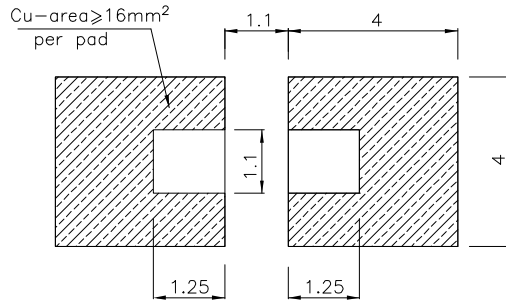
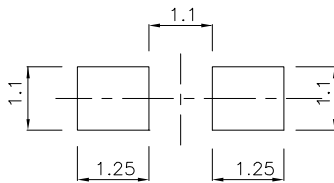

Solder resist

Tape Specifications (Units : mm)

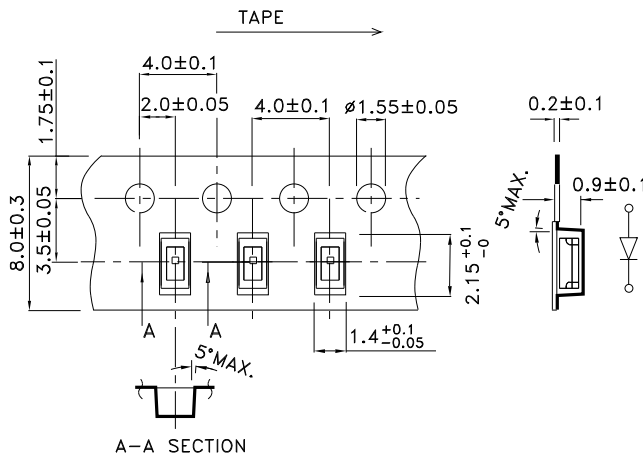

Reel Dimension

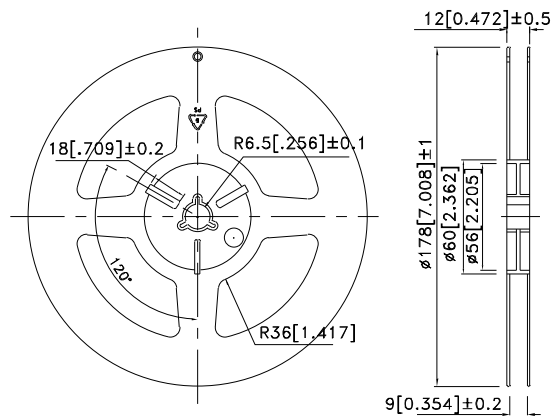

Kingbright

PACKING & LABEL SPECIFICATIONS

APTK2012RWC/Z-F01

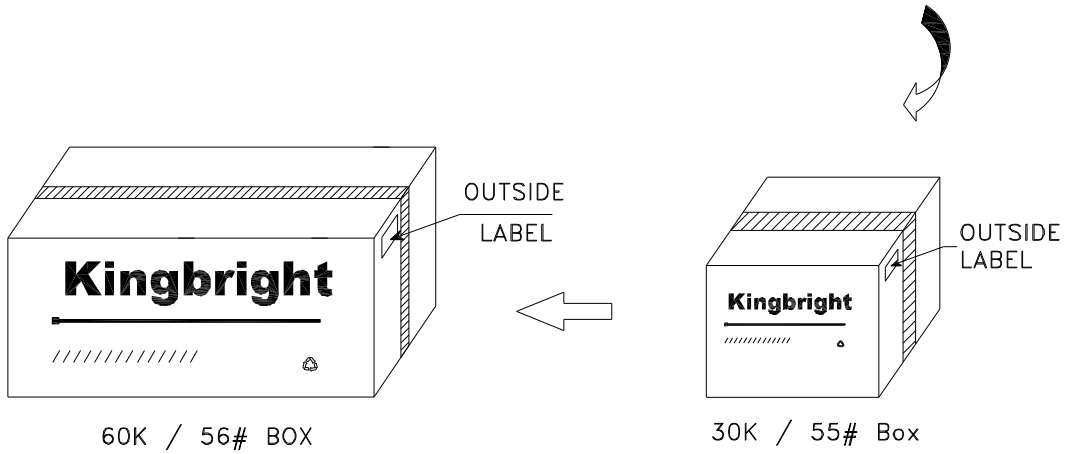
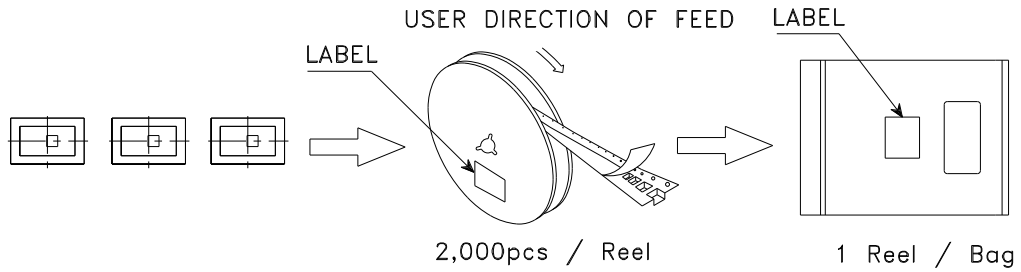

<h1>Kingbright</h1>	
P/NO: APTK2012xxx	
QTY: 2,000 pcs	Q.C. Q C xx xx xxxx PASSED
S/N: XXXX	
CODE: XXX	
LOT NO:	
 xxxxxxxxxxxxxxxxxxxxxxxx	
RoHS Compliant	