



ATTENTION
OBSERVE PRECAUTIONS
FOR HANDLING
ELECTROSTATIC
DISCHARGE
SENSITIVE
DEVICES

Part Number: AAA3528QWDCGKS-AMT

White
Green

Features

- Industry standard PLCC-4 package.
- High reliability LED package.
- Wide viewing angle.
- Both chips can be controlled separately .
- Suitable for all smt assembly and solder process.
- Available on tape and reel.
- Package : 2000pcs / reel.
- Moisture sensitivity level : Level 3.
- RoHS compliant.

Package Dimensions

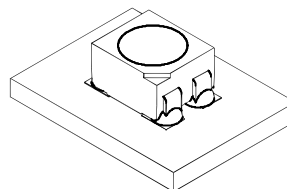
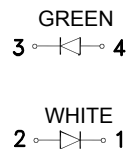
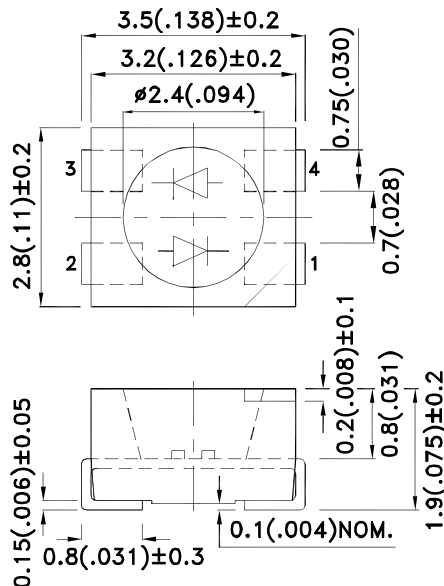

Notes:

1. All dimensions are in millimeters (inches).
2. Tolerance is $\pm 0.25(0.01)$ unless otherwise noted.
3. The specifications, characteristics and technical data described in the datasheet are subject to change without prior notice.
4. The device has a single mounting surface. The device must be mounted according to the specifications.



Handling Precautions

Compare to epoxy encapsulant that is hard and brittle, silicone is softer and flexible. Although its characteristic significantly reduces thermal stress, it is more susceptible to damage by external mechanical force.

As a result, special handling precautions need to be observed during assembly using silicone encapsulated LED products. Failure to comply might lead to damage and premature failure of the LED.

1. Handle the component along the side surfaces by using forceps or appropriate tools.

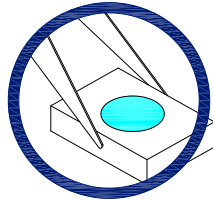

2. Do not directly touch or handle the silicone lens surface. It may damage the internal circuitry.

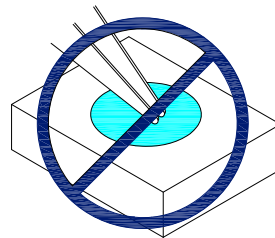
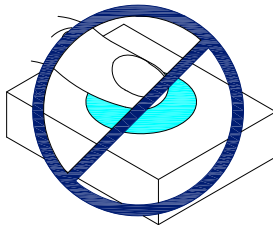

3. Do not stack together assembled PCBs containing exposed LEDs. Impact may scratch the silicone lens or damage the internal circuitry.

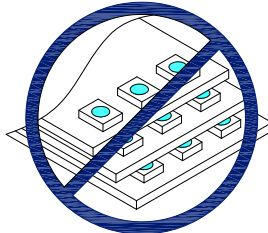

- 4.1. The inner diameter of the SMD pickup nozzle should not exceed the size of the LED to prevent air leaks.
- 4.2. A pliable material is suggested for the nozzle tip to avoid scratching or damaging the LED surface during pickup.
- 4.3. The dimensions of the component must be accurately programmed in the pick-and-place machine to insure precise pickup and avoid damage during production.

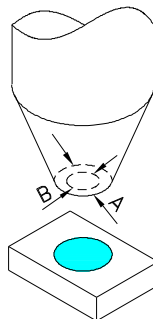

5. As silicone encapsulation is permeable to gases, some corrosive substances such as H_2S might corrode silver plating of leadframe. Special care should be taken if an LED with silicone encapsulation is to be used near such substances.

All design applications should refer to Kingbright application notes available at <http://www.KingbrightUSA.com/ApplicationNotes>

Selection Guide

Part No.	Dice	Lens Type	Iv (mcd) [2] @ 20mA			Viewing Angle [1]
			Code.	Min.	Max.	2θ1/2
AAA3528QWDCGKS-AMT	White (InGaN)	Water Clear	Q	300	400	120°
			R	400	500	
			S	500	700	
			T	700	1000	
	Green (AlGaInP)		G	40	55	
			H	55	80	
			M	80	120	
			N	120	200	

Notes:

1. θ1/2 is the angle from optical centerline where the luminous intensity is 1/2 of the optical peak value.
2. Luminous intensity/ luminous Flux: +/-15%.
3. Luminous intensity value is traceable to the CIE127-2007 compliant national standards.

Absolute Maximum Ratings at TA=25°C

Parameter	Symbol	Value		Unit	
		White	Green		
Power dissipation	P _D	120	125	mW	
Operating Temperature	T _{op}	-40 To+ 100		°C	
Storage Temperature	T _{stg}	-40 To+ 110		°C	
Junction temperature	T _J	110	120	°C	
DC Forward Current (TA=25°C)	I _F	30	50	mA	
Peak Forward Current [1] (TA=25°C)	I _{FM}	150	150	mA	
Reverse Voltage (TA=25°C)	V _R	5	5	V	
Electrostatic Discharge Threshold (HBM)		250	3000	V	
Thermal resistance (Junction/solder point)	1 chip on (typ.) 2 chip on (typ.) 1 chip on (max.) 2 chip on (max.)	R _{th j-s} R _{th j-s} R _{th j-s} [2] R _{th j-s} [2]	220 330 256 410	220 330 256 410	°C/W

Note:

1. 1/10 Duty Cycle, 0.1ms Pulse Width.
2. R_{th}(max) is based on statistic values.

Electrical / Optical Characteristics at TA=25°C (White)

Parameter	Symbol	Value	Unit
Chromaticity coordinate x acc.to CIE1931 I _F =20mA [Typ.]	x [1]	0.31	
Chromaticity coordinate y acc.to CIE1931 I _F =20mA [Typ.]	y [1]	0.31	
Reverse Current (V _R = 5V) [Max.]	I _R	50	uA
Forward Voltage I _F =20mA [Min.]	V _F [2]	-	V
Forward Voltage I _F =20mA [Typ.]		3.3	
Forward Voltage I _F =20mA [Max.]		4.0	
Temperature coefficient of V _F I _F =20mA, -10 ° C ≤ T ≤ 100 ° C [Typ.]	TC _V	-2.5	mV/° C
Temperature coefficient of x I _F =20mA, -10 ° C ≤ T ≤ 100 ° C [Typ.]	TC _X	-0.1	10 ⁻³ /° C
Temperature coefficient of y I _F =20mA, -10 ° C ≤ T ≤ 100 ° C [Typ.]	TC _Y	-0.2	10 ⁻³ /° C

Notes:

- 1.Measurement tolerance of the chromaticity coordinates is ±0.01.
- 2.Forward Voltage: +/-0.1V.

Electrical / Optical Characteristics at TA=25°C (Green)

Parameter	Symbol	Value				Unit
		Code.	Min.	Typ.	Max.	
Wavelength at peak emission IF=20mA	λ peak			574		nm
Dominant Wavelength IF=20mA	λ dom [1]	4	565		567	nm
		5	567		569	
		6	569		571	
		7	571		573	
Spectral bandwidth at 50% Φ REL MAX IF=20mA	$\Delta\lambda$			20		nm
Forward Voltage IF=20mA	V_F [2]			2.1	2.5	V
Reverse Current ($V_R = 5V$)	I_R				10	μA
Temperature coefficient of λ peak IF=20mA, $-10^\circ C \leq T \leq 100^\circ C$	$TC_{\lambda \text{ peak}}$			0.14		nm/ $^\circ C$
Temperature coefficient of λ dom IF=20mA, $-10^\circ C \leq T \leq 100^\circ C$	$TC_{\lambda \text{ dom}}$			0.05		nm/ $^\circ C$
Temperature coefficient of V_F IF=20mA, $-10^\circ C \leq T \leq 100^\circ C$	TC_V			-1.9		mV/ $^\circ C$

Notes:

1. The dominant Wavelength (λ d) above is the setup value of the sorting machine. (Tolerance λ d : ± 1 nm.)
2. Forward Voltage: $\pm 0.1V$.
3. Wavelength value is traceable to the CIE127-2007 compliant national standards.

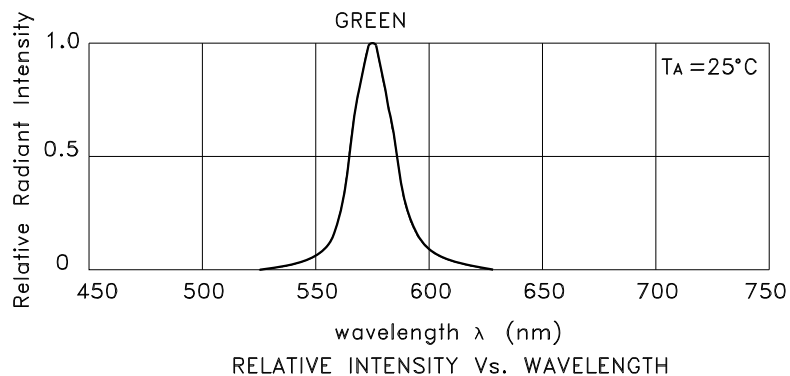

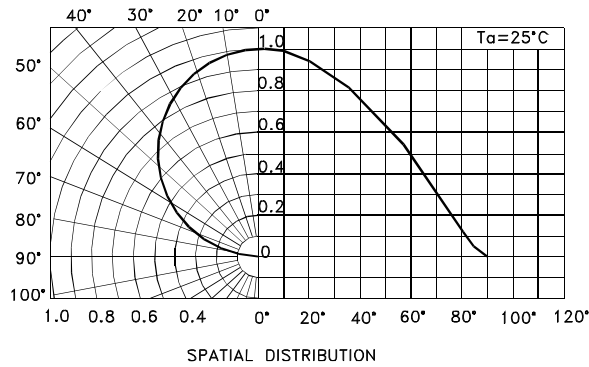

White

AAA3528QWDCGKS-AMT

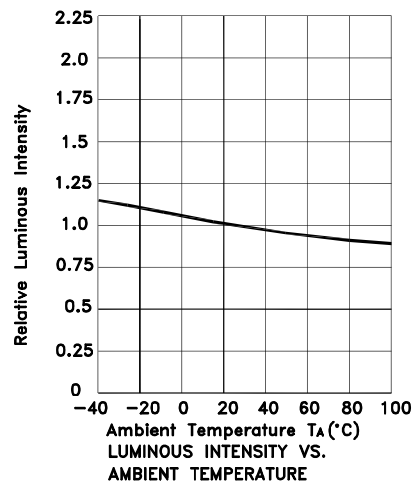
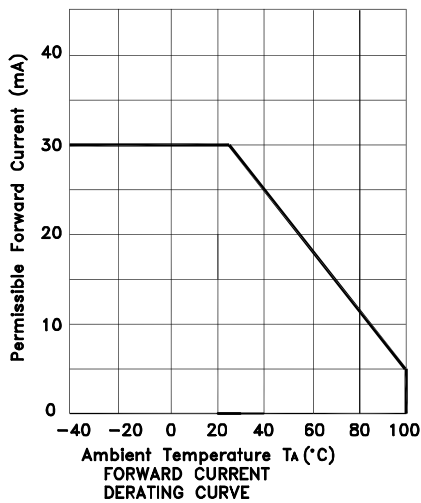
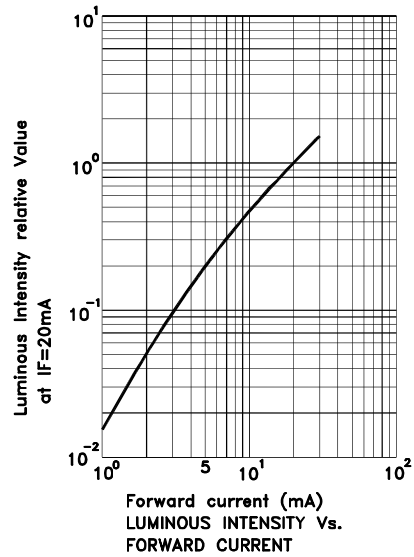
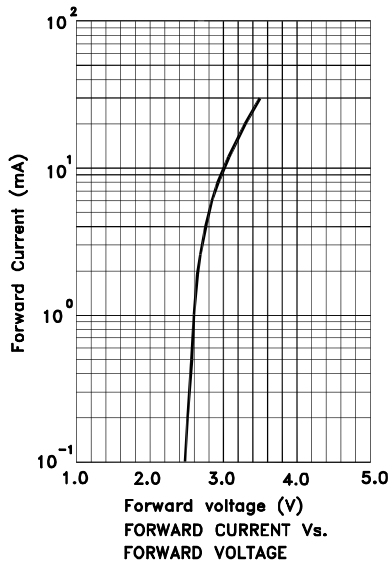

Kingbright

Green

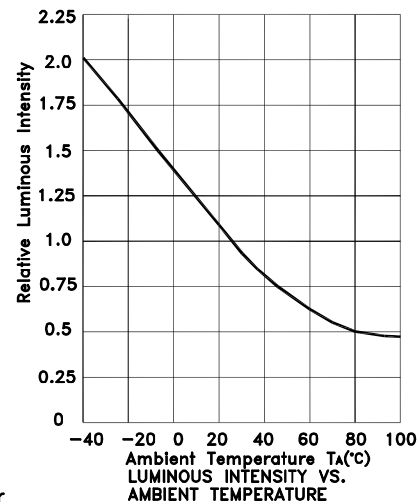
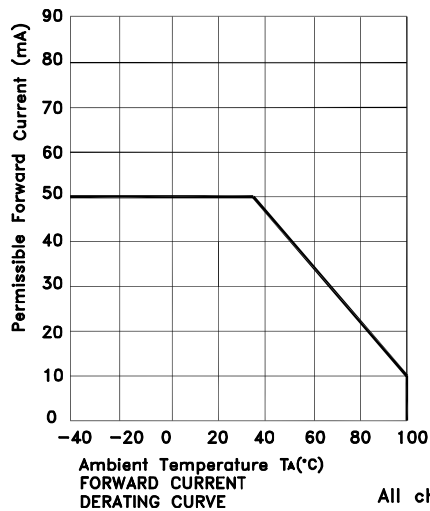
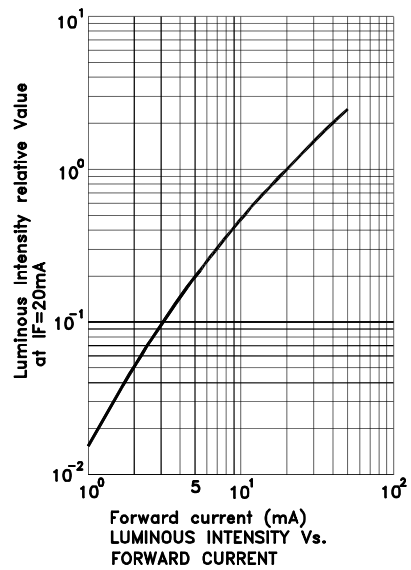
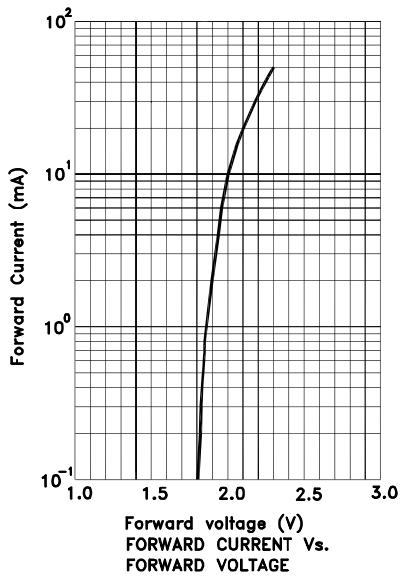

All chip together

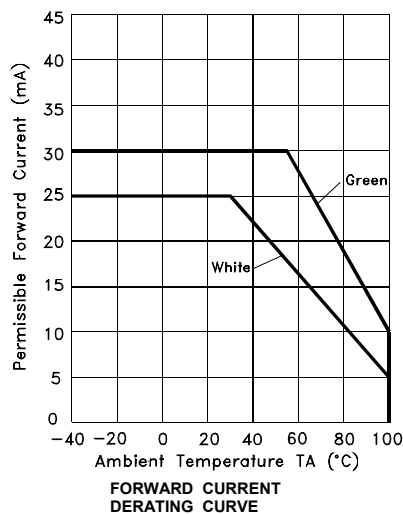

White

AAA3528QWDCGKS-AMT

White CIE

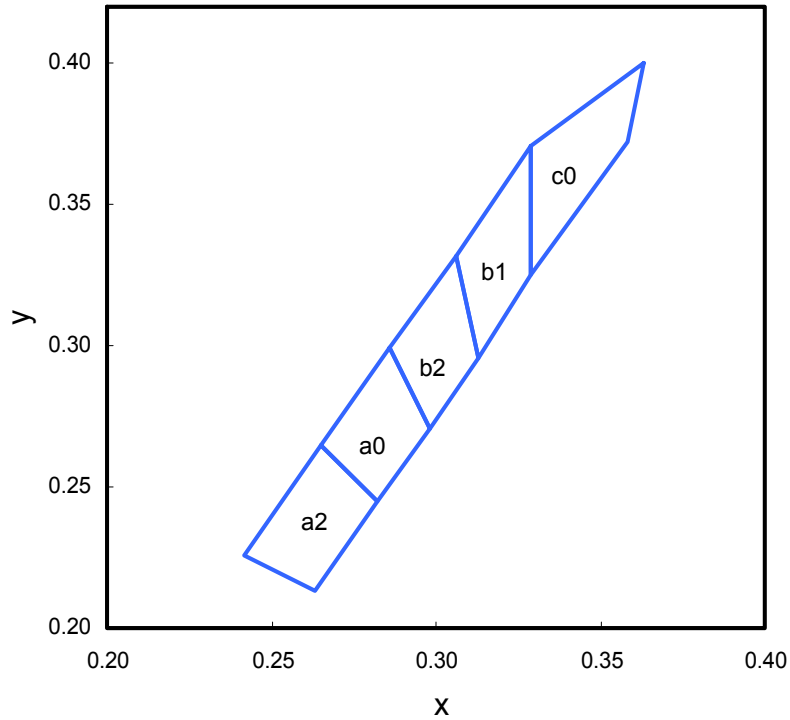

	x	y		x	y		x	y
a2	0.263	0.213	a0	0.282	0.245	b2	0.298	0.271
	0.282	0.245		0.298	0.271		0.313	0.296
	0.265	0.265		0.286	0.299		0.306	0.332
	0.242	0.226		0.265	0.265		0.286	0.299
b1	0.313	0.296	c0	0.329	0.325			
	0.329	0.325		0.358	0.372			
	0.329	0.371		0.363	0.400			
	0.306	0.332		0.329	0.371			

Notes:
 Shipment may contain more than one chromaticity regions.
 Orders for single chromaticity region are generally not accepted.
 Measurement tolerance of the chromaticity coordinates is ± 0.01 .

AAA3528QWDCGKS-AMT

Reflow soldering is recommended and the soldering profile is shown below.
Other soldering methods are not recommended as they might cause damage to the product.

Reflow Soldering Profile For Lead-free SMT Process.

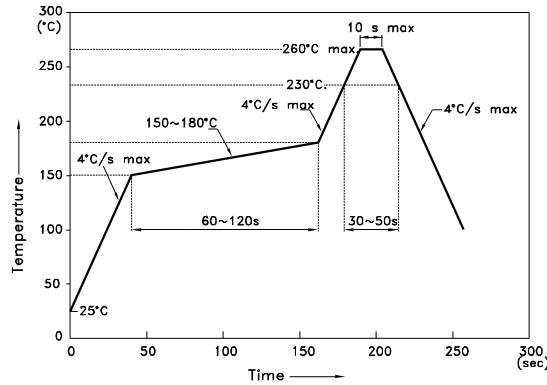

NOTES:

1. We recommend the reflow temperature 245°C(+/-5°C). The maximum soldering temperature should be limited to 260°C.
2. Don't cause stress to the epoxy resin while it is exposed to high temperature.
3. Number of reflow process shall be 2 times or less.

Recommended Soldering Pattern (Units : mm; Tolerance: ± 0.1)

Pad design for improved heat dissipation

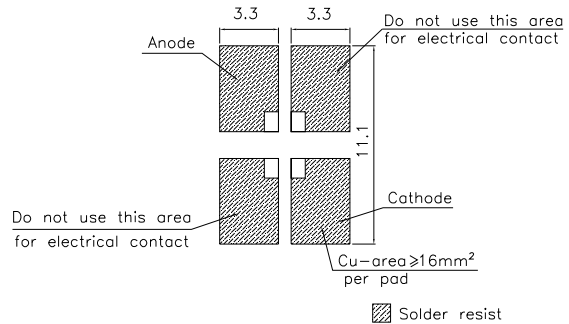
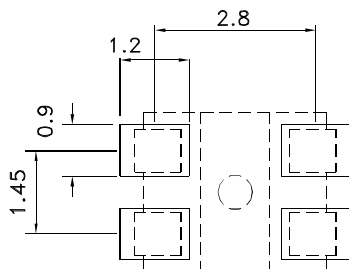

Tape Dimensions (Units : mm)

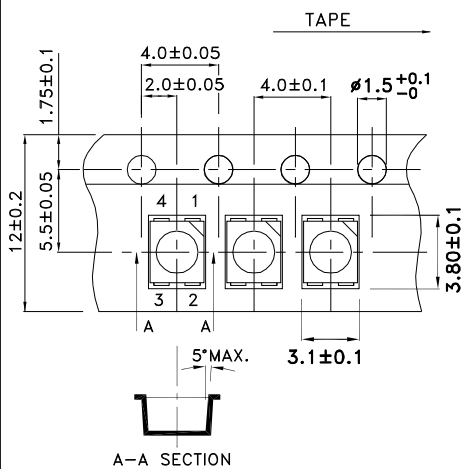

Reel Dimension

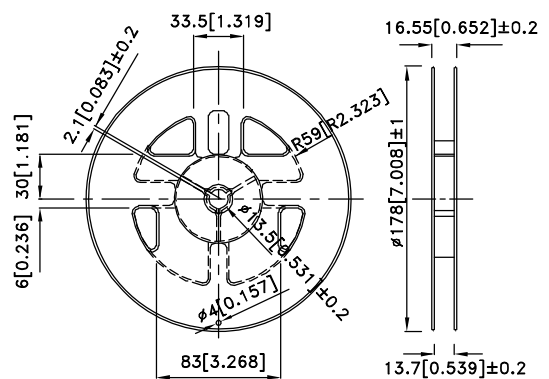

Kingbright

PACKING & LABEL SPECIFICATIONS

AAA3528QWDCGKS-AMT

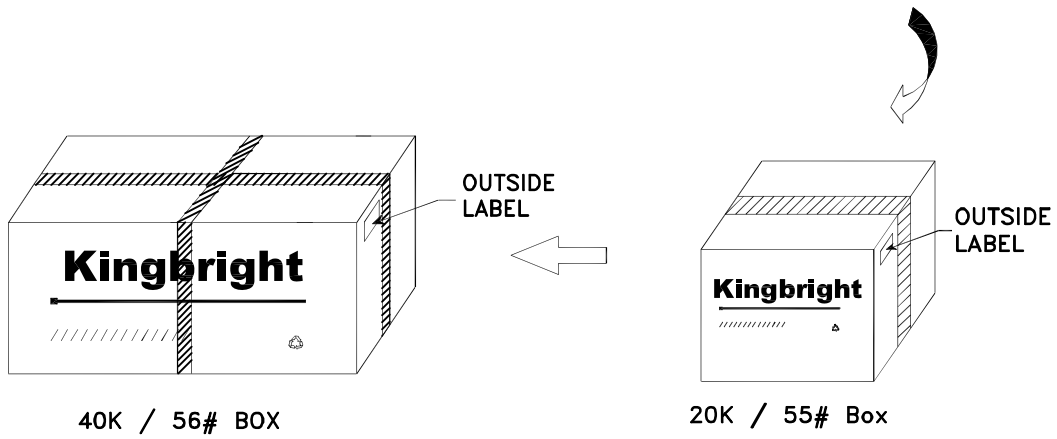
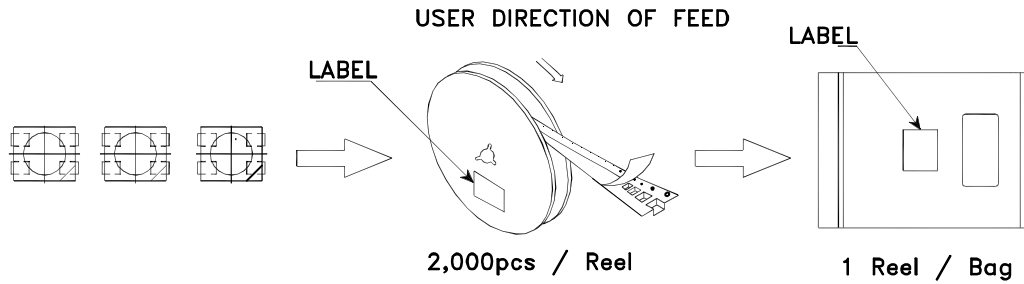

<h1>Kingbright</h1>	
P/NO: AAA3528XXX	
QTY: 2,000 pcs	Q.C. Q C XX XX XXXX PASSED
S/N: XXXX	
CODE: XXX	
LOT NO:	
 <small>XXXXXXXXXXXXXXXXXXXXXXXXXXXX</small>	
RoHS Compliant	

Reliability Test Items And Conditions

The reliability of products shall be satisfied with items listed below

Lot Tolerance Percent Defective (LTPD) : 10%

No.	Test Item	Standards	Test Condition	Test Times / Cycles	Number of Damaged
1	Continuous operating test	-	Ta = 25°C ,IF = maximum rated current*	1,000 h	0 / 22
2	High Temp. operating test	EIAJED-4701/100(101)	Ta = 100°C IF = maximum rated current*	1,000 h	0 / 22
3	Low Temp. operating test	-	Ta = -40°C, IF = maximum rated current*	1,000 h	0 / 22
4	High temp. storage test	EIAJED-4701/100(201)	Ta = maximum rated storage temperature	1,000 h	0 / 22
5	Low temp. storage test	EIAJED-4701/100(202)	Ta = -40°C	1,000 h	0 / 22
6	High temp. & humidity storage test	-	Ta = 60°C, RH = 90%	500 h	0 / 22
7	High temp. & humidity operating test	-	Ta = 60°C, RH = 90% IF = maximum rated current*	500 h	0 / 22
8	Soldering reliability test	EIAJED-4701/100(301)	Moisture soak : 30°C,70% RH, 72h Preheat : 150~180°C(120s max.) Soldering temp : 260°C(10s)	2 times	0 / 18
9	Thermal shock operating test	-	Ta = -40°C(15min) ~ 100°C(15min) IF = derated current at 100°C	1,000 cycles	0 / 22
10	Thermal shock test	-	Ta = -40°C(15min) ~ maximum rated storage temperature(15min)	1,000 cycles	0 / 22
11	Electric Static Discharge (ESD)	EIAJED-4701/100(304)	C = 100pF , R2 = 1.5KΩ V= 250V(White) V=3000V(Green)	Once each Polarity	0 / 22
12	Vibration test	-	a = 196m/s ² , f = 100~2KHz , t = 48min for all xyz axes	4 times	0 / 22

* : Refer to forward current vs. derating curve diagram

Failure Criteria

Items	Symbols	Conditions	Failure Criteria
luminous Intensity	Iv	IF = 20mA	Testing Min. Value <Spec.Min.Value x 0.5
Forward Voltage	VF	IF = 20mA	Testing Max. Value ≥Spec.Max.Value x 1.2
Reverse Current	IR	VR = Maximum Rated Reverse Voltage	Testing Max. Value ≥Spec.Max.Value x 2.5
High temp. storage test	-	-	Occurrence of notable decoloration, deformation and cracking